



**Cabazon Water District**  
14618 Broadway Street • P.O. Box 297  
Cabazon, California 92230

## **FINANCE & AUDIT COMMITTEE MEETING**

### **AGENDA**

#### **Meeting Location:**

Cabazon Water District Office  
14618 Broadway Street  
Cabazon, California 92230

#### **Meeting Date:**

Tuesday, February 19, 2019 – 5:00 PM

**CALL TO ORDER,**  
**PLEDGE OF ALLEGIANCE,**  
**ROLL CALL**  
**FINANCE & AUDIT COMMITTEE**

1. Discussion: Finance & Audit Committee Report
  - Balance Sheet
  - Profit and Loss Budget Comparison
2. Finance & Audit Committee District Payables Review and Approval/Signing

### **PUBLIC COMMENT**

Any person may address the Board of Directors at this time on any matter within the subject matter jurisdiction of the Cabazon Water District; however, any matter that requires action will be referred to staff for investigation and reported at a subsequent Board of Directors meeting. The Board of Directors is prohibited by law from discussing or taking immediate action on items during this public comment period. To comment on specific agenda items, please advise the Board secretary prior to the meeting. **Each public comment will be limited to three (3) minutes. Individuals may not give their time away to another spokesperson. After two (2) minutes, the speaker will be notified that he/she has one (1) minute remaining. AB 1234 ORAL REPORTS (Gov. Code Sec. 53232.3(d))**

### **ADJOURNMENT**

#### **ADA Compliance Issues**

In compliance with the Americans with Disabilities Act & Government Code Section 54954.2, if special assistance is needed to participate in a Board meeting, please contact the Clerk of the Board at (951) 849-4442. Notification of at least 48 hours prior to meeting time will assist staff in assuring that reasonable arrangements can be made to provide accessibility at the meeting.



**Cabazon Water District**  
14618 Broadway Street • P.O. Box 297  
Cabazon, California 92230

**REGULAR BOARD MEETING**

**AGENDA**

**Meeting Location:**  
Cabazon Water District Office  
14618 Broadway Street  
Cabazon, California 92230

**Meeting Date:**  
February 19, 2019 – 6:00 PM

**CALL TO ORDER**

**PLEDGE OF ALLEGIANCE**

**REMEMBRANCE OF OUR SERVICE MEN AND WOMEN**

**ROLL CALL**

**CONSENT CALENDAR**

All matters in this category are considered to be consistent with the Board/District goals, District Policies and Regulations adopted and/or approved by the Board of Directors, and will be enacted in one motion. There will be no separate discussion of these items. If discussion is required, items may be removed from the consent calendar and will be considered separately.

1. **Approval of:**
  - a. Finance and Audit Committee Meeting Minutes and Warrants approved by the committee January 15, 2019
  - b. Regular Board Meeting Minutes and Warrants of January 15, 2019
2. **Warrants – None**
3. **Awards of Contracts – None**

**UPDATES**

1. **Update:** San Gorgonio Pass Regional Water Alliance Update  
(by Director Davis)
2. **Update:** Manager's Operations Report  
(by General Manager Louie)

**NEW BUSINESS**

1. Discussion/Action: Customer Concern: Juan Perez, Dolores, Acct. No. 5-5032.5JP
2. Discussion/Action: Clarification on Efficiency Study on Water Rate Study (by GM Louie & Dir. Sanderson)

**OLD BUSINESS**

1. Discussion: Sustainable Groundwater Management Act (SGMA) Update (by General Manager Louie)
2. Discussion/Action: CalMutuals - Adan Ortega, Executive Director is forming the Community Water System Alliance (CWSA) – Prevent “Smaller & Poorer” to be unnecessarily taxed by the State and form a “mutual aid well-functioning water systems and those that may be at the brink of failing.” (by GM Louie & Board)
3. Discussion/Action: Adoption of current County of Riverside requirements on new single family dwelling construction to install a private fire protection system (fire sprinklers) - 3/4” water meter versus 1” water meter (by GM Louie) – question by Director Lynk – impact on property owner's fire insurance if the property owner signs a waiver
4. Discussion/Action: Customer Concern: Paul Oshideri – Unpaid Tenant Bills

**PUBLIC COMMENTS**

Any person may address the Board of Directors at this time on any matter within the subject matter jurisdiction of the Cabazon Water District that is not listed on the agenda; however, any matter that requires action will be referred to staff for investigation and reported at a subsequent Board of Directors meeting. The Board of Directors is prohibited by law from discussing or taking immediate action on items during this public comment period. To comment on specific agenda items, please advise the Board secretary prior to the meeting. Each public comment will be limited to three (3) minutes. Individuals may not give their time away to another spokesperson. After two (2) minutes, the speaker will be notified that he/she has one (1) minute remaining. AB 1234 ORAL REPORTS (Gov. Code Sec. 53232.3(d))

**GENERAL MANAGER/BOARD COMMENTS**

1. Future Agenda Items

The Board Chair or the majority of the Board may direct staff to investigate and report back to an individual(s) and the Board on matters suggested or direct the General Manager/Board Secretary to place the matter on a future Board meeting.

- Suggested agenda items from the Public.
- Suggested agenda items from Management.
- Suggested agenda items from Board Members.

2. Management Comments

Staff members may speak on items of information not requiring comment or discussion to the Board and public. Topics which may be included on a future meeting agenda may be presented but cannot be discussed. (3 minutes)

3. Board Member Comments

Board members may speak on items of information not requiring comment or discussion to the Board and public. (3 minutes)

MISCELLANEOUS

1. Future Board Items/Next Board Meeting Date(s)

- a. Finance & Audit Workshop – Tuesday – March 19, 2019, 5:00 pm
- b. Regular Board Meeting – Tuesday – March 19, 2019, 6:00 pm
- c. Personnel Committee – None
- d. San Geronio Pass Regional Water Alliance – Alliance Meeting – Wednesday – February 27, 2019

ADJOURNMENT

ADA Compliance Issues

*In compliance with the Americans with Disabilities Act & Government Code Section 54954.2, if special assistance is needed to participate in a Board meeting, please contact the Clerk of the Board at (951) 849-4442. Notification of at least 48 hours prior to meeting time will assist staff in assuring that reasonable arrangements can be made to provide access.*





**Cabazon Water District**  
14618 Broadway Street • P.O. Box 297  
Cabazon, California 92230

**FINANCE & AUDIT COMMITTEE MEETING**

**MINUTES**

**Meeting Location:**  
Cabazon Water District Office  
14618 Broadway Street  
Cabazon, California 92230

**Meeting Date:**  
Tuesday, January 15, 2019 – 5:00 PM

**CALL TO ORDER,**  
**PLEDGE OF ALLEGIANCE,**  
**ROLL CALL**

Director Wargo - Yes  
Director Israel - Yes

Calvin Louie (General Manager) - No  
Juliana Salcido, Board Secretary - Yes  
Cindy Byerrum, Financial Consultant - No

**\*Note: This meeting was recorded by the District - Yes**

**FINANCE & AUDIT COMMITTEE**

1. Discussion: Finance & Audit Committee Report
  - Balance Sheet
  - Profit and Loss Budget Comparison

**Balance Sheet:**

- The District's combined Cash with Chase and LAIF balance was \$856,636 at month end. The District's total liabilities were approximately \$1.171 million at month end.

Profit and Loss:

- Line 11 Returned Check Fees: These fees are difficult to budget for accurately due to their unexpected nature when revenue is earned.
- Line 13 Standby Fees: The bulk of these receipts often occur around January and April and can occasionally cause YTD to trend over/under budget.
- Line 49 Well Maintenance: YTD is over budget due to \$34.5K in invoices from Legend Pump & Well Services for Well 5 Rehabilitation. Rehabilitation included pulling the pump to perform maintenance & restore water flow.
- Line 92 Safety: YTD is over budget due to a \$9.8K contract with Lancaster Safety Consulting for OSHA certified training which was not budgeted.

As of December 31<sup>st</sup>, the fiscal year-to-date net income is \$17,113.

2. Finance & Audit Committee District Payables Review and Approval/Signing

PUBLIC COMMENT

Any person may address the Board of Directors at this time on any matter within the subject matter jurisdiction of the Cabazon Water District; however, any matter that requires action will be referred to staff for investigation and reported at a subsequent Board of Directors meeting. The Board of Directors is prohibited by law from discussing or taking immediate action on items during this public comment period. To comment on specific agenda items, please advise the Board secretary prior to the meeting. **Each public comment will be limited to three (3) minutes. Individuals may not give their time away to another spokesperson. After two (2) minutes, the speaker will be notified that he/she has one (1) minute remaining. AB 1234 ORAL REPORTS (Gov. Code Sec. 53232.3(d))**

ADJOURNMENT

Motion to adjourn at 17:10 hr. made by Director Wargo and 2<sup>nd</sup> by Director Israel.

Director Wargo - Aye

Director Israel - Aye

Meeting adjourned at 17:10hr on Tuesday, January 15, 2019

---

Robert Lynk, Board Chair  
Board of Directors  
Cabazon Water District

---

Juliana Salcido, Secretary  
Board of Directors  
Cabazon Water District

ADA Compliance Issues

In compliance with the Americans with Disabilities Act & Government Code Section 54954.2, if special assistance is needed to participate in a Board meeting, please contact the Clerk of the Board at (951) 849-4442. Notification of at least 48 hours prior to meeting time will assist staff in assuring that reasonable arrangements can be made to provide accessibility at the meeting.



**Cabazon Water District**  
14618 Broadway Street • P.O. Box 297  
Cabazon, California 92230

**REGULAR BOARD MEETING  
MINUTES**

**Meeting Location:**  
Cabazon Water District Office  
14618 Broadway Street  
Cabazon, California 92230

**Meeting Date:**  
January 15, 2019 – 6:00 PM

**CALL TO ORDER**

**PLEDGE OF ALLEGIANCE**

**REMEMBRANCE OF OUR SERVICE MEN AND WOMEN**

**ROLL CALL**

Director Martin Sanderson - Present  
Director Maxine Israel - Present  
Director Sarah Wargo - Present  
Director Alan Davis - Present  
Director Robert Lynk - Present

Calvin Louie, General Manager - Absent  
Juliana Salcido, Board Secretary - Present  
Cindy Byerrum, Financial Consultant - Absent  
Steve Anderson, Best Best & Krieger Law Firm - Absent  
Joseph Ortiz, Best Best & Krieger Law Firm - Absent

\*Note: Calvin Louie was absent so that he could respond to a non-business hour water emergency, but informed the board that he would attend the meeting when he was finished.

Note: This meeting was recorded by the District - Yes

**CONSENT CALENDAR**

All matters in this category are considered to be consistent with the Board/District goals, District Policies and Regulations adopted and/or approved by the Board of Directors, and will be enacted in one motion. There will be no

separate discussion of these items. If discussion is required, items may be removed from the consent calendar and will be considered separately.

**1. Approval of:**

- a. Finance and Audit Committee Meeting Minutes and Warrants approved by the committee December 17, 2019
- b. Regular Board Meeting Minutes and Warrants of December 17, 2018

**Motion to approve consent calendar item(s) (a.) Finance and Audit Committee Meeting Minutes and Warrants approved by the committee December 17, 2018. (b.) Regular Board Meeting Minutes and Warrants of December 17, 2018 made by Director Israel and 2<sup>nd</sup> by Director Wargo.**

Director Sanderson - Aye  
Director Israel - Aye  
Director Wargo - Aye  
Director Davis - Aye  
Director Lynk - Aye

2. Warrants – None
3. Awards of Contracts – None

**UPDATES**

1. Update: San Gorgonio Pass Regional Water Alliance Update  
(by Director Israel)

**\*Note: No Update**

2. Update: Manager's Operations Report  
(by General Manager Louie)

**\*Note: Board Secretary, Juliana Salcido presented the Manager's Report due to Louie's absence.**

- Update on Well# 5 Rehabilitation: Encrustation that is plugging the louvers still remains. Sonar Jet is recommended to break up the crust. Management and Engineers are currently obtaining a cost for the Sonar Jet services.
- A total number of work orders for the year 2018 is 1052.



**NEW BUSINESS**

**1. Discussion/Action: Customer Concern: Paul Oshideri – Unpaid Tenant Bills**

- The Board Secretary was informed by Oshideri that he would not be attending the meeting.
- The Board decided to table this for next month's meeting as an Old Agenda item.

**\*Note: No motion was made.**

**2. Discussion/Action: Adoption of current County of Riverside requirements on new single family dwelling construction to install a private fire protection system (fire sprinklers) - 3/4" water meter versus 1" water meter**

**\*Note: The Board decided to table until Calvin returned and moved forward to Old Business.**

- The board is concerned how this will effect manufactured homes with a consolidated system
- Director Lynk suggests that a flow restrictor be placed between the meter and the domestic shut off valve to lower the volume
- Director Lynk expressed concern if a home is burned down and the homeowner has to bring it up to code, they will have to pay the different cost from a 5/8 meter to a 1" Meter.
- Louie clarified the standards are brought by the county and not the engineers.
- Director Lynk brought up the concern of how signing this waiver will affect people's homeowner insurance.
- Board came to the agreement to table this until next month's meeting after Calvin talks to engineers about a split system of a restriction in the domestic side, so that the customers do not get charged for something they do not have access too.

**\*Note: No motion was made.**

**OLD BUSINESS**

1. Discussion: Sustainable Groundwater Management Act (SGMA) Update  
(by General Manager Louie)
  
2. Discussion: Update on Interconnection between Morongo Tribal reservoir and Tank #2  
and Providing or allowing electric power (Edison) to their production well  
and reservoir control panel

**\*Note: The Board decided to table until Louie returned and preceded to Agenda Old Business:**

➤ Item: 3 CalMutuals - Adan Ortega, Executive Director is forming the Community Water System Alliance (CWSA) – Prevent “Smaller & Poorer” to be unnecessarily taxed by the State and form a *“mutual aid well-functioning water systems and those that may be at the brink of failing.”*

- Calvin informed the board that he would be meeting with John Covington, Sabrina Neis, and Bob Krieger on the matter. The results of this meeting will be discussed in February's meeting with hopefully all the parties present.

3. Discussion/Action: CalMutuals - Adan Ortega, Executive Director is forming the Community Water System Alliance (CWSA) – Prevent “Smaller & Poorer” to be unnecessarily taxed by the State and form a *“mutual aid well-functioning water systems and those that may be at the brink of failing.”*

- Director Davis has been calling other Water Districts and speaking to the General Managers and Board Members to get their opinions.
- He discovered that everybody he has contacted has applied and most of them have already paid.
- Even the bigger Districts have applied to help the lower income districts.
- The Board agreed to table for next month's meeting after Director Davis has talked to more General Managers and Board Members.

**\*Note: After this Discussion a quick recess was taken at 18:25 hr. and the meeting resumed at 18:35 hr.**

## PUBLIC COMMENTS

**\*Note: No Public was present**

Any person may address the Board of Directors at this time on any matter within the subject matter jurisdiction of the Cabazon Water District that is not listed on the agenda; however, any matter that requires action will be referred to staff for investigation and reported at a subsequent Board of Directors meeting. The Board of Directors is prohibited by law from discussing or taking immediate action on items during this public comment period. To comment on specific agenda items, please advise the Board secretary prior to the meeting. Each public comment will be limited to three (3) minutes. Individuals may not give their time away to another spokesperson. After two (2) minutes, the speaker will be notified that he/she has one (1) minute remaining. AB 1234 ORAL REPORTS (Gov. Code Sec. 53232.3(d))

## GENERAL MANAGER/BOARD COMMENTS

### 1. Future Agenda Items

The Board Chair or the majority of the Board may direct staff to investigate and report back to an individual(s) and the Board on matters suggested or direct the General Manager/Board Secretary to place the matter on a future Board meeting.

- Suggested agenda items from the Public.
- Suggested agenda items from Management.
- Suggested agenda items from Board Members.

➤ Director Israel stepped down as the first point of contact with the San Gorgonio Pass Regional Water Alliance. Director Davis will now be the lead, and Director Israel will be the second point of contact.

### 2. Management Comments

Staff members may speak on items of information not requiring comment or discussion to the Board and public. Topics which may be included on a future meeting agenda may be presented but cannot be discussed. (3 minutes)

- Calvin informed the board that Ellie Lemus will be back from military leave in March 2019.
- Louie also notified the board that our Water Billing software is no longer being supported by Continental Utility Solutions Inc. (CUSI) Replacing this system can be a potential expense that will be up to about 50,000. Calvin is waiting for Ellie to come back so that she can discuss it with Cindy Byerrum.

### 3. Board Member Comments

Board members may speak on items of information not requiring comment or discussion to the Board and public. (3 minutes)

- Director Sanderson asked about the status of the Rate Study.
- Calvin will follow up and this will be an agenda item for next month's meeting.

**MISCELLANEOUS**

1. Future Board Items/Next Board Meeting Date(s)
  - a. Finance & Audit Workshop – Tuesday – February 19, 2019, 5:00 pm
  - b. Regular Board Meeting – Tuesday – February 19, 2019, 6:00 pm
  - c. Personnel Committee – None
  - d. San Gorgonio Pass Regional Water Alliance – Alliance Meeting – Wednesday – January 23, 2019

**ADJOURNMENT**

Motion to adjourn at 18: 57hr. made by Director Israel and 2<sup>nd</sup> by Director Sanderson.

\*Note: No roll call vote was made, but there were no objections voiced by either Board or Public to adjourn the meeting.

Meeting adjourned at 18:57 hr. on Tuesday, January 15, 2019

---

Robert Lynk, Board Chair  
Board of Directors  
Cabazon Water District

---

Juliana Salcido, Secretary  
Board of Directors  
Cabazon Water District

ADA Compliance Issues

*In compliance with the Americans with Disabilities Act & Government Code Section 54954.2, if special assistance is needed to participate in a Board meeting, please contact the Clerk of the Board at (951) 849-4442. Notification of at least 48 hours prior to meeting time will assist staff in assuring that reasonable arrangements can be made to provide access.*



# Cabazon Water District

## Profit & Loss

January 2019

	Jan-19	Current YTD	Budget	YTD (58%)
<b>1 REVENUES</b>				
<b>2 OPERATING INCOME</b>				
3 Base Rate - Water Bills	72,837	484,765	811,800	60%
4 Commodity Sales	6,097	192,369	327,500	59%
5 DHPO Contract	23,111	138,814	225,900	61%
6 Fire Sales - Water Bills	237	1,591	2,500	64%
7 Fire Flow Income	-	-	400	0%
8 Penalty Fees - Water Bills	3,676	27,233	48,300	56%
9 New Account Fees - Water Bills	40	910	1,800	51%
10 Incident Fee - Water Bills	-	-	400	0%
11 Returned Check Fees	60	360	600	60%
12 Basic Facilities Fee	-	3,974	64,900	6%
13 Stand By Fees - Tax Revenue	-	19,190	113,600	17%
<b>14 TOTAL OPERATING INCOME</b>	<b>106,059</b>	<b>869,206</b>	<b>1,597,700</b>	<b>54%</b>
<b>15 NON-OPERATING INCOME</b>				
16 Property Taxes	21,894	23,091	60,900	38%
17 Cell Tower Lease Income	2,046	14,324	22,100	65%
18 Misc. Non-Operating Income	0	26	-	0%
19 Interest Income	3,898	9,984	11,200	89%
<b>20 TOTAL NON-OPERATING INCOME</b>	<b>27,839</b>	<b>47,425</b>	<b>94,200</b>	<b>50%</b>
<b>21 TOTAL REVENUES</b>	<b>133,897</b>	<b>916,630</b>	<b>1,691,900</b>	<b>54%</b>
<b>22 EXPENSES</b>				
<b>23 PAYROLL</b>				
24 Directors Fees	-	8,200	20,000	41%
25 Management & Customer Service				
26 Customer Accounts	4,095	31,331	51,700	61%
27 Business Admin Manager	-	35,254	66,800	53%
28 Office Assistant	2,483	15,479	-	0%
29 General Manager	9,897	53,154	84,100	63%
30 Total Management & Customer Service	16,475	135,217	202,600	67%
31 Field Workers	10,885	85,366	146,300	58%
32 Employee Benefits Expense				
33 Workers Comp.	113	4,402	8,800	50%
34 Employee Health Care	8,311	55,549	86,800	64%
35 Pension	3,202	29,922	67,800	44%
36 Total Employee Benefits Expense	11,627	89,873	163,400	55%
37 Payroll Taxes	3,333	20,616	29,300	70%
<b>38 TOTAL PAYROLL</b>	<b>42,319</b>	<b>339,272</b>	<b>561,600</b>	<b>60%</b>
<b>39 OPERATIONAL EXPENSES</b>				
40 Facilities, Wells, T&D				
41 Lab Fees	187	4,609	8,500	54%
42 Site Landscaping & Maintenance	-	270	700	39%
43 Meters	-	300	4,600	7%

# Cabazon Water District

## Profit & Loss

January 2019

	Jan-19	Current YTD	Budget	YTD (58%)	
44	Generator Service Contractor	-	1,525	1,300	117%
45	Utilities - Wells	8,763	66,778	126,100	53%
46	SCADA	30	194	300	65%
47	Line R&M Contractor	-	-	12,500	0%
48	Line R&M Materials	3,851	18,092	60,000	30%
49	Well Maintenance	2,450	42,855	36,200	118%
50	Security	2,564	12,254	18,400	67%
51	Engineering Services	6,024	28,301	48,600	58%
52	Chlorinators	-	-	100	0%
53	Facilities, Wells, T&D - Other	-	5,012	10,000	50%
54	<b>Total Facilities, Wells, T&amp;D</b>	<b>23,868</b>	<b>180,190</b>	<b>327,300</b>	<b>55%</b>
55	Utilities - Office				
56	Electricity	1,109	10,765	15,900	68%
57	Gas	-	239	710	34%
58	Telephone	822	5,581	9,500	59%
59	Trash Pickup & Office Cleaning	364	2,576	4,400	59%
60	<b>Total Utilities - Office</b>	<b>2,294</b>	<b>19,160</b>	<b>30,510</b>	<b>63%</b>
61	Office Expenses				
62	Water Billing System	177	1,241	2,100	59%
63	Supplies & Equipment	933	9,576	9,700	99%
64	Copier Lease & Printing Supplies	237	2,696	6,000	45%
65	Dues & Subscriptions	250	340	1,700	20%
66	Postage	613	3,966	7,700	52%
67	Printing & Publications	-	3,880	6,100	64%
68	Leases & Rents	-	165	300	55%
69	Computer Services	2,697	16,148	36,800	44%
70	Office Radio	-	-	500	0%
71	Office Storage	500	3,500	6,200	56%
72	Air Conditioning Servicing	398	2,786	4,600	61%
73	Fire Alarm System Servicing	-	312	700	45%
74	Office Expenses - Other	-	546	1,300	42%
75	<b>Total Office Expenses</b>	<b>5,806</b>	<b>45,156</b>	<b>83,700</b>	<b>54%</b>
76	Support Services				
77	Temporary Labor	-	-	10,000	0%
78	Financial Audit	500	8,355	22,100	38%
79	Accounting	-	23,673	36,000	66%
80	Legal Services	3,087	38,147	53,600	71%
81	Bank Service Charges	50	474	700	68%
82	Payroll Service	474	2,565	4,100	63%
83	Website Support	75	450	1,700	26%
84	General Liability Insurance	1,946	13,149	21,000	63%
85	<b>Total Support Services</b>	<b>6,132</b>	<b>86,813</b>	<b>149,200</b>	<b>58%</b>
86	Training/Travel	534	5,677	41,000	14%

## Cabazon Water District

### Profit & Loss

January 2019

	Jan-19	Current YTD	Budget	YTD (58%)
87 Other Fees/SWRCB	-	5,990	6,200	97%
88 Service Tools & Equipment				
89 Shop Supplies and Small Tools	1,458	5,107	21,100	24%
90 Vehicle Fuel	1,774	8,278	12,800	65%
91 Employee Uniforms	100	1,394	1,500	93%
92 Safety	-	9,864	500	1973%
93 Tractor Expenses	30	4,166	1,000	417%
94 Equipment Rental	-	-	2,100	0%
95 Service Trucks - R&M	-	3,628	13,900	26%
96 Water Ops Phone & Internet	88	616	900	68%
97 Total Service Tools & Equipment	3,450	34,126	53,800	63%
98 <b>NON-OPERATING EXPENSES</b>				
99 Grant & Loan Processing Fee	-	1,325	1,600	83%
100 DWR Interest Expense	-	4,978	10,300	48%
101 DHPO Interest Expense	-	5,162	9,800	53%
102 Bad Debt Expense	-	-	1,200	0%
103 Miscellaneous	-	-	1,600	0%
104 Depreciation Expense	22,192	155,342	266,300	58%
105 <b>TOTAL NON-OPERATING EXPENSES</b>	22,192	166,807	290,800	57%
106 <b>TOTAL EXPENSES</b>	106,596	883,192	1,544,110	57%
107 <b>TOTAL INCOME BEFORE CAPITAL &amp; GSA</b>	27,302	33,438	147,790	23%
108 DHPO Capacity Credit	(1,750)	(12,250)	(21,000)	58%
<b>CAPITAL PROJECTS</b>				
109 Main Street Improvements (Icehouse Imp.)	-	(29,280)	(60,000)	49%
110 Meter Replacements & Other Capital	-	(9,048)	(22,000)	41%
111 Vehicle Upgrades	-	(8,419)	-	0%
112 <b>TOTAL CAPITAL PROJECTS</b>	-	(46,748)	(82,000)	57%
113 <b>DEBT - PRINCIPAL</b>				
114 Debt Service Principal - DWR	-	(19,367)	(38,400)	50%
115 Debt Service Principal - DHPO (Zion)	-	(39,435)	(78,900)	50%
116 <b>TOTAL DEBT - PRINCIPAL</b>	-	(58,802)	(117,300)	50%
117 <b>SGMA / GSA</b>	-	(8,632)	(60,000)	14%
118 <b>NET INCOME / (LOSS)</b>	<b>25,552</b>	<b>(92,994)</b>	<b>(132,510)</b>	

*No assurance is provided on these financial statements.*

*The financial statements do not include a statement of cash flows.*

*Substantially all disclosures required by accounting principles generally accepted in the United States are not included.*



# Cabazon Water District

## Balance Sheet

January 31, 2019

Jan 31, 19

1	<b>ASSETS</b>	
2	Current Assets	
3	Checking/Savings	
4	General Bank Account-Chase	128,846
5	Payroll Bank Account-Chase	129,309
6	Trust Account-Chase (Cust. Deposits)	17,214
7	Local Petty Cash	100
8	Total Checking/Savings	<u>275,469</u>
9	Accounts Receivable	203,595
10	LAIF	565,249
11	Bank of NY Trustee Accounts	61,438
12	Prepaid Expenses	10,085
13	Inventory Total	93,672
14	Total Other Current Assets	<u>932,432</u>
15	Total Current Assets	<u>1,213,177</u>
16	Fixed Assets	
17	Construction in Process	
18	CIP Cabazon Outlets Expansion	9,692
19	CIP Super Map	19,015
20	CIP 50100 Main St. Property	85,460
21	Total Construction in Process	<u>114,167</u>
22	Tools and Equipment	123,319
23	Source of Supply	1,552,226
24	Transmission & Distribution	10,216,143
25	Buildings & Structures	12,281
26	Water Treatment	8,800
27	Office Furniture and Equipment	71,808
28	Intangible Plant	11,032
29	Vehicles	106,309
30	Land	689,548
31	Accumulated Depreciation	<u>(5,507,480)</u>
32	Total Fixed Assets	<u>7,398,152</u>
33	<b>TOTAL ASSETS</b>	<u><u>8,611,329</u></u>
34	<b>LIABILITIES &amp; EQUITY</b>	
35	Liabilities	
36	Current Liabilities	
37	Accounts Payable	-
38	Other Current Liabilities	
39	Customer Deposits - Co 1	4,950
40	Customer Deposits - Co 2	4,784
41	Total Customer Deposits	<u>9,734</u>
42	Accrued Vacation Pay	10,051
43	DWR-HS Payable - Current	38,425
44	Current Portion Zion's Bank Ln	78,870
45	Accrued Payroll	7,565



# Cabazon Water District

## Balance Sheet

January 31, 2019

		<b>Jan 31, 19</b>
46	Accrued Payroll Taxes	553
47	Accrued Interest	5,225
48	Accrued Expenses	6,419
49	Employee Deductions	68
50	Total Other Current Liabilities	<u>156,910</u>
51	Total Current Liabilities	156,910
52	Long Term Liabilities	
53	DWR-H Loan Payable (Payoff '26)	318,500
54	Zion's Bank Long Term (2023)	335,745
55	RCEDA Loan Payable	300,000
56	Total Long Term Liabilities	<u>954,245</u>
57	Total Liabilities	<u>1,111,156</u>
58	Total Equity	<u>7,500,174</u>
59	<b>TOTAL LIABILITIES &amp; EQUITY</b>	<b><u>8,611,329</u></b>



# THE SACRAMENTO BEE



**CAPITOL ALERT**

February 7, 2019 11:28 AM

# Californians with bad water ask for help while opposition mounts to Newsom's proposed tax



**Capitol Alert**

The go-to source for news on California policy and politics

## Californians with bad water ask for help while opposition mounts to Newsom's proposed tax

By Maddy Ashmun [mashmun@sacbee.com](mailto:mashmun@sacbee.com)

Californians with unhealthy drinking water pleaded for help from lawmakers this week but opposition quickly developed to Gov. Gavin Newsom's proposal to pay for system improvements with a new fee.

"We just upped our water rates, and to turn around and give them a tax on their meter is just not feasible," said Maxine Israel, director at the Cabazon Water District, which serves about 2,500 customers near Palm Springs.

She was among dozens of water experts and advocates who crowded a hearing on Wednesday to discuss how the state can deliver system improvements that would help nearly 1 million Californians who lack access to safe drinking water.

Newsom last month released a state budget that called for a new fee on drinking water to fund drinking water projects. He did not release many details, but the proposal was characterized as similar to a 2017 bill by Sen. Bill Monning, D-Carmel, that would have generated \$140 million a year for water projects.

Newsom just after releasing the spending plan called attention to the drinking water proposal by visiting communities in Stanislaus County that are known for delivering water from wells that are contaminated with nitrates and arsenic.

"It's a disgrace that in a state as wealthy and resourceful as ours that a million-plus people don't have access to safe, clean drinking water," he said during his January visit to a neighborhood in Ceres known as the Monterey Park Tract.

Andy Alfaro, Mike Dunbar, and Erin Tracy

Monning's proposal included a 95 cent monthly tax on residential customers, along with other fees attached to fertilizer purchases and dairy and feedlot production.

"We believe the ratepayer piece is the critical component to creating a guaranteed and predictable source of funding," Monning said.

He argued that the proposed fund, which has been called a "water tax" by critics, would make money consistently available for the operation and maintenance of water treatment plants in addition to the construction and improvement of them.

A couple dozen residents from the San Joaquin Valley attended the hearing. Several of them spoke in Spanish in rushed testimony while lawmakers tried to wrap up what became a three hour event.

"Please help us have safe drinking water for all human beings," one said.

Simona Magaña, a Tulare County resident, expressed her support of the tax. The owner of a private well, said she was without water for two years and relied on her neighbor who would bring clean water over in barrels.

“I would sit down and cry a lot from the sadness that we live in the richest country in the world and have to go through this,” she said.

But some advocates aren’t convinced that a tax is the best way to address the state’s clean water crisis.

“Why create a new tax when you have a huge budget surplus?” says Cindy Tuck, a deputy executive director at the Association of California Water Agencies (ACWA).

California state government is on track to accumulate a \$14.8 billion surplus, and the state is on pace to fill reserve accounts with an additional \$16 billion, according to a November report from the Legislative Analyst’s Office.

The water agency association and the California Municipal Utilities Association support alternative legislation that would establish a “drinking water trust,” which would be funded initially with an infusion from the general fund during a surplus year.

Paul Jones, general manager of the Eastern Municipal Water District in Riverside County previewed the proposal and said it could cover operations, maintenance, and consolidation costs, among other things.

The outline cheered lawmakers who want to pay for drinking water improvements without making a new fee.

“I like the trust idea, I think it’s definitely viable” Assemblyman Devon Mathis, R-Visalia, said. “Quite frankly I think anything is better than a tax.”





## MEMORANDUM

DATE: January 9, 2019  
TO: Board of Directors  
FROM: C. Louie  
SUBJ: Community Water Service Alliance (CWSA)  
cc: files

---

Attached are the string of email communications and various documents for your review.

Date	Classification	Description
11/29/2018	Email	CWSA Meeting 11/30/2018 – Agenda & Location
11/30/2018	Document	Proposed CWSA agenda
12/03/2018	Document	Report: Organization of a Community Water Systems Alliance and proposed tier sponsor rates
12/10/2018	Email	CWSA Agenda & Meeting Documents
12/10/2018	Document	Draft of CWSA MOU
12/12/2018	Document	Twentynine Palms Water District notes on their Board's decision to join and fund CWSA
12/12/2018	Email	CWSA Meeting Summary from 12/11
01/02/2019	Email	CWSA MOU v.3 (12/17/2018)
01/02/2019	Document	MOU v.3 (12/17/2018)
01/03/2019	Email	CWSA Update & Issues to Review
01/08/2019	Email	CWSA Meeting Agenda
01/08/2019	Document	2019 CWSA Budget Draft
01/08/2019	Document	CWSA membership recruitment flyer

Cabazon Water District  
14618 Broadway Street  
P.O. Box 297  
Cabazon, California 92230

Bus. (951) 849-4442

Fax (951) 849 2519

## Calvin Louie

---

**From:** adan <adan@calmutuals.org>  
**Sent:** Thursday, November 29, 2018 2:02 PM  
**To:** Jones, Paul; Coats, Danielle; Zelaya, Sheila; Ray Kolisz; Lisa Yamashita Lopez; David A. Armstrong; Tim Worley; Katie Porter; Dan Ferons; donb@smwd.com; Leach, Jim; Kelly Gardner; Meggan Valencia; Jeff Armstrong; Denise Peralta; Jim Ciampa; Lisa Ohlund; Stacy Taylor; Calvin Louie  
**Subject:** Reminder: CWSA Meeting 11/30 11-1pm Agenda and Location  
**Attachments:** CWSAAGenda11\_30\_Reminder.pdf

Thank you for planning to participate in the potential formation of an alliance for community water systems  serving small, older and poorer communities in California. Attached is an agenda that is reserving the majority of time for discussion. The meeting will be held at Eastern Municipal Water District Headquarters, and Eastern is graciously hosting lunch. I look forward to seeing you tomorrow.

Address:  
EASTERN MUNICIPAL WATER DISTRICT  
2270 Trumble Road  
Perris, CA 92570

Adan Ortega  
Executive Director  
CalMutuals  
714 449-8403  
adan@calmutuals.org

via Newton Mail

**Proposed Community Water System Alliance**

**Agenda**

**11 am – 1 pm**

**November 30, 2018**

**Location:**

**EASTERN MUNICIPAL WATER DISTRICT**

**2270 Trumble Road**

**Perris, CA 92570**

1. **Introductions** 5 min  
**Welcome by Host:** Paul Jones, EMWD  
Attendees
  
2. **Brief Background on Formation of CWSA** 10 min  
Lisa Yamashita-Lopez & Adan Ortega, CalMutuals  
Ray Kolisz, TPWD
  
3. **Discussion About Key Issues of Common Interests** 15 min.  
Dan Ferons, SMWD / FVMWC  
- Water Tax  
- SWRCB Economic Feasibility Guidelines for New MCL Standards  
- Others?
  
4. **Funding Options Discussion** 15 min  
Adan Ortega, CalMutuals
  
5. **Next Steps** Up to 1:15  
Open Discussion





**Report: Organization of a Community Water Systems Alliance  
December 3, 2019**

A meeting was held on Friday, November 30, 2018, to discuss possible support for an alliance of community water systems representing income limited and disadvantaged communities, at Eastern Municipal Water District. The meeting was attended by:

Paul Jones, General Manager, Eastern Municipal Water District  
Danielle Coats, Senior Legislative Program Manager, Eastern Municipal Water District  
Lisa Yamashita Lopez, President, CalMutuals & GM Rubio Cañon Land and Water Assn.  
David Armstrong, Vice President, CalMutuals & GM South Mesa Water Co.  
Jim Ciampa, General Counsel, CalMutuals & Public Water Agency Group (PWAG)  
Owen Sharp, General Manager, San Andreas Mutual Water Company  
Sandy Caruba, Board Member, San Andreas Mutual Water Company  
Carol Giannini, Board Member, Twentynine Palms Water District  
Bob Coghill, Board Member, Twentynine Palms Water District  
Ray Kolisz, General Manager, Twentynine Palms Water District  
Denise Peralta Galley, Advocate, Twentynine Palms Water District  
Dan Ferons, General Manager, Santa Margarita Water District  
Don Barns, Assistant General Manager, Santa Margarita Water District  
Jim Leach, Director of Government Affairs, Santa Margarita Water District  
Kelly Gardner, Assistant Executive Director, San Gabriel Valley Water Association  
Paul Gonsalves, Advocate, San Gabriel Valley Water Association  
Stacy Taylor, External Affairs Manager, Mesa Water District  
Jeff Armstrong, General Manager, Rancho California Water District  
Meggan Valencia, Public Affairs Manager, Rancho California Water District  
Calvin Louie, General Manager, Cabazon Water District  
Curt Saur, Joshua Basin Water District  
Jeff Deming, Principal, Monterey Bay Academy  
Jackie McCloud, Utilities Manager, City of Watsonville  
Lisa Ohlund, General Manager, East Orange Water District  
Tim Worley, Executive Director, AWWA Cal-Nevada Section  
Adan Ortega, Executive Director, CalMutuals

**Meeting Purpose:** To potentially augment resources through CalMutuals to include income-limited and disadvantaged communities, who are served by well run and operated water supply agencies, in organized efforts to prevent that their resources will be diverted by the state through the assessment of local taxes or economically infeasible regulations (i.e. Chromium 6).

**Community Water Systems Alliance (CWSA) Principles**

The group discussed seven principles around which CWSA would organize and advocate. CWSA will be comprised of a group of special districts, county water districts, community service districts, and cities that are well run and operated while serving disadvantaged communities and other populations that entail revenue limitations, such as seniors.



General draft organizing principles were revised to include the following:

1. CWSA is comprised of viable and well running water supply systems focused on empowering those among them who directly represent and serve the residents of disadvantaged communities and other populations with income limitations such as seniors
2. CWSA supports a statewide comprehensive needs-assessment of the operational integrity and resiliency of chronically distressed water systems
3. CWSA supports funding to build water system resiliency that does not shift existing resources of disadvantaged communities from some regions to other regions of the state
4. CWSA supports regulations that are deemed economically feasible through a combination of factors including affordability, transparent understanding of health benefits and their real-time cost and value to the residents of California
5. CWSA supports consolidation of chronically distressed water systems when it is part of an initiative supported by the residents of such communities, and where property rights and the right of representation is respected
6. CWSA members pledge to work with larger neighboring and/or regional water agencies toward efforts that bring resource efficiency, stewardship of local shared resources that are based upon common values, needs and respect not charity
7. CWSA is an alliance for education and advocacy of the common interests and empowerment of water systems serving disadvantaged communities and other income limited populations, not a permanent water association

**Management** – The group generally agreed that as fiscal sponsor, CalMutuals could bring efficiency to CWSA by availing it of its administrative, advocacy and logistical support eliminating the need for the duplication of resources, in parallel with CalMutuals’ regional capacity across the state. CalMutuals is proposing that an advisory board be comprised of the initial charter members according to the contribution levels below.

**Budget** - The group felt that the estimated budget of \$60,000 for one year to cover the legislative calendar was modest given the issues driving the organization of CWSA. The group asked CalMutuals to propose a sponsorship schedule scaled to the revenue capacity of prospective members (see contributions below).

Proposed Schedule for Regular Sponsors of the Initiative

CalMutuals has a “progressive” membership schedule that encourages participation by small and larger members. Pending consensus from the group, CalMutuals proposes the following scales of sponsorship for the initiative:

Tier 1: Revenues <\$250K	\$500
Tier 2: Revenues \$250K +	\$750
Tier 3: Revenues \$500K+	\$1,250
Tier 4: Revenues \$1M+	\$2,500
Tier 5: Revenues \$4M+	\$5,000

## Calvin Louie

---

**From:** adan <adan@calmutuals.org>  
**Sent:** Monday, December 10, 2018 2:25 PM  
**To:** Jackie McCloud; coatsd@emwd.org; David A. Armstrong; donb@smwd.com; Joe A. Gonsalves & Son; Jim Byerrum; Jim Ciampa; Leach, Jim; Kelly Jensen; Katie Porter; Ray Kolisz; Stacy Taylor; Meggan Valencia; Calvin Louie; Reeb, Bob; Danielle Blacet; Oz; Curt Sauer; Nunneley, Doug; mwest@bdvwa.org; mwest@bdvwa.org  
**Cc:** Susan Allen  
**Subject:** CWSA Agenda & Meeting Documents  
**Attachments:** CWSA MOU (12-3-18) v.docx; CWSA Report1Summary.docx

### Community Water System Alliance Participants and Potential Participants -

Below is call-in information, a draft agenda, a draft MOU, as well as the meeting report with proposed tiers for participation in the initiative - this information is also imbedded in the Calendar invitation. **As a reminder:** Our goal is to empower persons elected to represent disadvantaged communities to have a voice about issues such as the proposed water tax and the draft economic feasibility guidelines when they are released by the State Water Board.

Call-in Information: 1 858-284-1527. PIN: 764 612 631#

#### Draft Agenda:

1. Introductions
2. Membership Tiers (Please see CWSA Report1Summary.docx - Attached)
3. Draft MOU for Participation by Agencies (Please see CWSA MOU- Attached)
4. AB134 (Bloom)
5. Discussions with Committee Staff and Assm. E. Garcia
6. Next Steps

Adan Ortega  
Executive Director  
CalMutuals  
714 449-8403  
adan@calmutuals.org

via Newton Mail



**MEMORANDUM OF UNDERSTANDING  
COMMUNITY WATER SYSTEMS ALLIANCE**

This Memorandum of Understanding ("MOU") is entered into this \_\_\_ day of \_\_\_\_\_, 2018 ("Effective Date") by and between the California Association of Mutual Water Companies, a California non-profit mutual benefit corporation ("Cal Mutuals"), and \_\_\_\_\_ ("Participant") with respect to the following.

**RECITALS**

- A. There are numerous regulatory and legislative issues facing water suppliers in California, including, but not limited to, water quality standards, requirements to limit water losses, a potential water tax, funding mechanisms for low-income rate assistance and long-term water use efficiency requirements.
- B. There are numerous water suppliers serving disadvantaged and severely disadvantaged communities that while operating efficiently and well, do not, on an individual basis, have the financial resources to be able to effectively advocate with respect to the issues identified in Recital A.
- C. Cal Mutuals is a non-profit association formed to provide effective advocacy for, and to facilitate operational and educational resources to ensure effective and compliant operation and governance of, mutual water companies and other small water systems in California.
- D. Cal Mutuals has worked with various water systems to develop a collaborative program to assist water systems serving disadvantaged and severely disadvantaged communities with regulatory and legislative advocacy, as described in Section 1, below (the "Initiative").
- E. The Community Water Systems Alliance ("CWSA") is an alliance of water systems who are undertaking the Initiative, working with and through Cal Mutuals as described herein.
- F. Participant desires to participate in CWSA and desires to make a financial contribution to help offset the costs of the Initiative, in accordance with the provisions set forth below.

NOW, THEREFORE, Participant and Cal Mutuals agree as follows:

1. The Initiative. Cal Mutuals will provide the services necessary to administer and coordinate the functions relating to the Initiative, as guided by the principles attached hereto as Exhibit A and incorporated herein by this reference. Participant, in its sole discretion and at its sole cost, may provide services of its employees to assist with implementing the Initiative.



2. Participant's Financial Contribution. Participant shall contribute the sum of \$ \_\_\_\_\_ to CWSA, through Cal Mutuals, in order to join and participate in CWSA. That amount may be paid in a lump sum or through a payment arrangement to be agreed upon by Participant and Cal Mutuals. Cal Mutuals shall separately account for all such contributions and shall utilize Participant's and other CWSA members' contributions only for costs related to the Initiative and its administration. Cal Mutuals shall issue a quarterly report of CWSA's income and expenses, including the use of Participant's contribution, on or before the thirtieth (30<sup>th</sup>) day following the end of each calendar quarter (i.e., March 31, June 30, September 30 and December 31). Participant acknowledges that the financial contributions of other CWSA members may vary and may be greater than or less than Participant's contributions, although Cal Mutuals will use its best efforts to ensure a fair structure concerning such overall contributions, including through application of the revenue-based contribution model set forth in Exhibit A hereto.

3. CWSA Participant Issues. Participant shall allow Cal Mutuals to use Participant's name in any correspondence that Cal Mutuals may send regarding the Initiative and in any materials used in soliciting additional members in CWSA; provided, however, that if such correspondence relates to a position on legislation, Participant shall be provided the opportunity to opt out of being specifically named in any such correspondence and Cal Mutuals will remove Participant's name if so instructed. Upon written request of Participant, Cal Mutuals shall promptly (i.e., within three business days) provide Participant by e-mail with a list of all participants in CWSA and their respective contributions.

4. Audit/Inspection. Upon at least forty-eight (48) hours' prior written notice, Participant may audit or inspect, at Participant's sole cost and expense, Cal Mutuals' accounting books and records relating to CWSA and the Initiative.

5. Term; Termination. This MOU shall have an indefinite term, although it is contemplated to last approximately two years. Because CWSA is intended to be a temporary program, it may be terminated at any time by the vote of at least sixty percent (60%) of its members. Participant may withdraw from CWSA at any time, upon at least seven (7) days' written notice. Such withdrawal shall not entitle Participant to a refund of any portion of its contribution under Section 2, above, unless any audit or inspection under Section 4, above, reveals the misappropriation of funds by Cal Mutuals, in which case CWSA shall be entitled to the return of its entire contribution or such other amount thereof as the parties may agree.

6. Indemnification. Cal Mutuals shall indemnify and defend Participant against any third party claims, losses, liabilities damages, lawsuits, claims, judgments or other costs resulting from Cal Mutuals' gross negligence or intentional misconduct in performing its duties hereunder.

7. Notices. Any notice or other communication to be provided under this MOU shall be in writing, and shall be deemed effectively given upon personal delivery; or upon deposit in any United States mail box, by registered, certified, Priority, or Express mail, postage prepaid; or upon delivery by nationally recognized overnight courier; or upon confirmed transmission by facsimile, addressed to the other party at the address shown below.



8. Governing Law. This MOU shall be governed by and construed in accordance with the laws of the State of California.

9. Amendment. This MOU may be modified only by a written agreement signed by both parties.

10. Severability. If any court determines that any provision of this MOU is invalid or unenforceable, any invalidity or unenforceability will affect only that provision and will not make any other provision of this MOU invalid or unenforceable and such provision shall be modified, amended or limited only to the extent necessary to render it valid and enforceable

11. Counterparts; Execution Transmitted by E-Mail or Fax. This MOU may be executed in counterparts, effective as of the Effective Date first set forth above. The parties agree that this MOU will be considered signed when the signature of a party is delivered by e-mail or by facsimile transmission. Such e-mailed or facsimile signature shall be treated in all respects as having the same effect of an original signature.

IN WITNESS WHEREOF, the Participant and Cal Mutuals have executed this MOU as of the date first above written.

California Association of Mutual Water Companies

By \_\_\_\_\_  
Lisa Yamashita-Lopez, President

Address: 1370 N. Brea Blvd., Suite 238  
Fullerton, CA 92835  
Fax Number: \_\_\_\_\_

Participant

By \_\_\_\_\_  
Its \_\_\_\_\_

Address: \_\_\_\_\_  
\_\_\_\_\_  
Fax Number: \_\_\_\_\_

**TWENTYNINE PALMS WATER DISTRICT**  
72401 HATCH ROAD, TWENTYNINE PALMS, CA 92277-2935  
760.367.7546 PHONE 760.367.6612 FAX

TO:	BOARD OF DIRECTORS
DATE:	DECEMBER 19, 2018
FROM:	RAY KOLISZ, GENERAL MANAGER
SUBJECT:	DISCUSSION OF COMMUNITY WATER SYSTEM ALLIANCE FORMATION AND APPROVAL TO CONTRIBUTE FUNDING

**BACKGROUND AND DISCUSSION**

As previously reported as part of the SMART initiative, we have been working to form an alliance of community water systems to give voice to elected officials who represent disadvantaged communities as is the case with Twentynine Palms Water District (TPWD). This is particularly important given that proposals to tax water at the meter have already surfaced for re-consideration by the legislature during 2019. We are also expecting the State Water Board to release draft economic feasibility guidelines that will impact the standard for Chromium 6 and other constituents.

On November 30, 2018, TPWD helped to organize and lead a gathering of 22 general managers and board members representing 14 water agencies stretching from Watsonville to the high desert and the Inland Empire to "jump-start" the Community Water System Alliance (CWSA). The California Association of Mutual Water Companies ("CalMutuals") is willing to act as fiscal sponsor. This avoids having to start a new water association. CalMutuals will manage accounting and the advocacy coordination on behalf of the group.

Among several needs, CWSA will use the funds to develop briefing materials reflecting the needs of disadvantaged communities, such as TPWD, that are successfully fending for ourselves. The funds will also be used to help poorer water districts send their representatives to public hearings in Sacramento and around the state. The original draft budget estimated costs at \$60,000 for one year, which those assembled on November 30<sup>th</sup> thought was too modest given the level of interest and need to have participation at the hearings and meetings ahead especially in Sacramento.

The group has so far agreed that residents of well-functioning disadvantaged communities should not be taxed to benefit chronically failing water systems in other parts of the state. We have agreed to work to find alternative funding sources that will also be available to agencies such as TPWD. The group has also agreed to look at other forms of mutual aid between well-functioning water systems and those that may be at the brink of failing.



## **RECOMMENDATION**

Agencies that sponsor the initiative at \$10,000 or more will be part of a policy council that will guide the CWSA. TPWD has been urging others to support the effort, and it is thus my recommendation that TPWD agree to engage at the \$10,000 level. Upon approval from the Board the CWSA will draft a Memorandum of Understanding (MOU) to be presented to the Board for consideration.

**Calvin Louie**

---

**From:** adan <adan@calmutuals.org>  
**Sent:** Wednesday, December 12, 2018 2:39 PM  
**To:** Jones, Paul; Coats, Danielle; Lisa Yamashita Lopez; David A. Armstrong; Jim Ciampa; Ray Kolisz; Dan Ferons; donb@smwd.com; Leach, Jim; Kelly Gardner; Stacy Taylor; Jeff Armstrong; Meggan Valencia; Calvin Louie; Jackie McCloud; Lisa Ohlund; Tim Worley; mwest@bdvwa.org; Nunneley, Doug  
**Cc:** Danielle Blacet; Katie Porter; Joe A. Gonsalves & Son; Kelly Jensen; Jim Byerrum; Reeb, Bob; Susan Allen  
**Subject:** CWSA Meeting Summary from 12/11  
**Attachments:** CWSA MOU (12-3-18) v.docx

Team -



The group considered several items during the CWSA call yesterday as appeared on the agenda:

**Membership Tiers**

There were no objections to the following sponsorship tiers for the CWSA initiative Schedule for Regular Sponsors of the Initiative:

Tier 1: Revenues <\$250K	\$500
Tier 2: Revenues \$250K +	\$750
Tier 3: Revenues \$500K+	\$1,250
Tier 4: Revenues \$1M+	\$2,500
Tier 5: Revenues \$4M+	\$5,000

**Charter Members Defined**

Several water agencies will seek approval from their boards in the coming weeks to jump-start the CWSA initiative at levels of \$10,000 or more. Those agencies that donate more than \$10,000 will serve as the "executive committee" to review expenses and administrative matters through CalMutuals

**Draft MOU for Participation by Agencies**

No objections were raised to requests that "opt-out" provisions be inserted into the Participation MOU also applying to communications being sent to third-parties where positions, requests or group-inquiries are being made in written form. The current draft included an opt-out on legislative positions.

Given pending actions by boards considering participation in CWSA will take place over the next two weeks, it is requested that any further requests for revisions to the MOU be set to Adan Ortega by 5 pm on Monday, December 17, 2018. (The draft MOU is attached for your convenience)

**AB134 (Bloom)**

AB134 is a spot bill with no specific provisions (yet). But it is a potential vehicle that will be tracked.

**Discussions with Committee Staff and Assm. E. Garcia**

As previously reported, a joint committee hearing will be held early in '19 comprised of the Assembly Water, Parks & Wildlife Committee, Assem. Environmental Quality Committee, and Budget Committee #3. Participation by disadvantaged communities that were not part of last year's debate is strongly encouraged.



Assem. Garcia will also be visiting other areas with Disadvantaged Communities that are succeeding and struggling. These may include Southeast Los Angeles/San Gabriel Valley, Los Desert Areas and the Central Coast.

**Next Steps**

1. Comments on draft MOU are due Mon. Dec. 17th at 5pm (please send to Adan Ortega)
2. Identify representatives from agencies serving Disadvantaged Communities that may be available for hearings/testimony.
3. Schedule follow-up call on the week of Jan. 7th. Potential agenda items include a) status on hearings; b) status of regional visits by Assm. Garcia & legislative Taskforce c) roster of agencies that have joined CWSA; d) briefing on human right to water proposals by ACWA and others; e) consideration of initial talking points; d) other items as suggested during the interim.

Adan Ortega  
Executive Director  
CalMutuals  
714 449-8403  
adan@calmutuals.org

via Newton Mail

On Mon, Dec 3, 2018 at 12:48 PM, adan <adan@calmutuals.org> wrote:  
Team -

Once again, I'd like to thank Eastern Municipal Water District for hosting a meeting last Friday (Nov. 30) about the possible formation of an alliance of water supply systems that directly represent Disadvantaged Communities and other populations with income limitations. Attached is a document summarizing the discussion we had at Eastern. I think we made great progress to launch this initiative. Please review the principles as I tried to reflect the comments made during the meeting. We are planning to have a conference call during the week of December 10th. If you did not attend the meeting on the 30th but would like to participate on the call during the week of December 10th, please reply to this email and let me know. In the meantime, please feel free to call me if you have any questions (714 600-4683).

Thank you!

Adan Ortega  
Executive Director  
CalMutuals  
714 449-8403  
adan@calmutuals.org

via Newton Mail

## Calvin Louie

---

**From:** adan <adan@calmutuals.org>  
**Sent:** Wednesday, January 2, 2019 3:45 PM  
**To:** Lisa Ohlund; Ray Kollisz; Calvin Louie; Dan Ferons; Jones, Paul; Coats, Danielle; Curt Sauer; Nunneley, Doug  
**Cc:** Susan Allen; Jim Ciampa  
**Subject:** CWSA MOU  
**Attachments:** CWSA MOU v.3 (12-17-18).docx

Here is the final version of the MOU for the Community Water Systems Alliance. It addresses three factors raised during our last conference call: 1) Expanded opt-out; 2) Indemnification; 3) Clarifies the sponsorship tiers and the advisory board status/role of those who contribute \$10k or more. We will schedule a call for late next week with the advisory group to review the initial budget, and initial proposed steps that we will take to the broader group. Please feel free to call me at 714 600-4683 if you have any questions.  
Adan

Adan Ortega  
Executive Director  
CalMutuals  
714 449-8403  
adan@calmutuals.org

via Newton Mail



**MEMORANDUM OF UNDERSTANDING  
COMMUNITY WATER SYSTEMS ALLIANCE**

This Memorandum of Understanding (“MOU”) is entered into this \_\_\_ day of \_\_\_\_\_, 2018 (“Effective Date”) by and between the California Association of Mutual Water Companies, a California non-profit mutual benefit corporation (“Cal Mutuals”), and \_\_\_\_\_ (“Participant”) with respect to the following.

**RECITALS**

- A. There are numerous regulatory and legislative issues facing water suppliers in California, including, but not limited to, water quality standards, requirements to limit water losses, a potential water tax, funding mechanisms for low-income rate assistance and long-term water use efficiency requirements.
- B. There are numerous water suppliers serving disadvantaged and severely disadvantaged communities that, while operating efficiently and well, do not, on an individual basis, have the financial resources to be able to effectively advocate with respect to the issues identified in Recital A.
- C. Cal Mutuals is a non-profit association formed to provide effective advocacy for, and to facilitate operational and educational resources to ensure effective and compliant operation and governance of, mutual water companies and other small water systems in California.
- D. Cal Mutuals has worked with various water systems to develop a collaborative program to assist water systems serving disadvantaged and severely disadvantaged communities with regulatory and legislative advocacy, as described in Section 1, below (the “Initiative”).
- E. The Community Water Systems Alliance (“CWSA”) is an alliance of water systems who are undertaking the Initiative, working with and through Cal Mutuals as described herein.
- F. Participant desires to participate in CWSA and desires to make a financial contribution to help offset the costs of the Initiative, in accordance with the provisions set forth below.

NOW, THEREFORE, Participant and Cal Mutuals agree as follows:

1. The Initiative. Cal Mutuals will provide the services necessary to administer and coordinate the functions relating to the Initiative, as guided by the principles attached hereto as Exhibit A and incorporated herein by this reference. Participant, in its sole discretion and at its sole cost, may provide services of its employees to assist with implementing the Initiative. Participant shall cooperate with Cal Mutuals in coordinating and organizing any such services that are to be provided in conjunction with the Initiative.



2. Participant's Financial Contribution; Charter Membership. (a) Cal Mutuals has established the following dues structure for Participants to join and participate in CWSA:

<u>REVENUE TIERS</u>	<u>DUES</u>
<u>Tier 1: Annual Gross Revenues of less than \$250,000</u>	<u>\$500</u>
<u>Tier 2: Annual Gross Revenues between \$250,000 and \$499,999</u>	<u>\$750</u>
<u>Tier 3: Annual Gross Revenues between \$500,000 and \$999,999</u>	<u>\$1,250</u>
<u>Tier 4: Annual Gross Revenues between \$1,000,000 and \$3,999,999</u>	<u>\$2,500</u>
<u>Tier 5: Annual Gross Revenues of \$4,000,000 and higher</u>	<u>\$5,000</u>
<u>Charter Member (see subsection (c))</u>	<u>At least \$10,000</u>

(b) Participant's annual gross revenues place it in Tier , and Participant shall therefore pay dues of \$ . [or: Participant has agreed to contribute \$ in consideration of its Charter Membership pursuant to subsection (c), below]. shall contribute the sum of \$ to CWSA, through Cal Mutuals, in order to join and participate in CWSA. That amount may be paid in a lump sum or through a payment arrangement to be agreed upon by Participant and Cal Mutuals. The amount shall be payable by check payable to Cal Mutuals or by wire transfer or other electronic funds transfer in the manner directed by Cal Mutuals. Cal Mutuals shall separately account for all such contributions and shall utilize Participant's and other CWSA members' contributions only for costs related to the Initiative and its administration. Cal Mutuals shall issue a quarterly report of CWSA's income and expenses, including the use of Participant's contribution, on or before the thirtieth (30<sup>th</sup>) day following the end of each calendar quarter (i.e., March 31, June 30, September 30 and December 31). Participant acknowledges that, with the exception of the dues structure set forth in subsection (a), above, the financial contributions of other CWSA members may vary and may be greater than or less than Participant's contributions, although Cal Mutuals will use its best efforts to ensure a fair structure concerning such overall contributions, including through application of the revenue-based contribution model set forth in Exhibit A hereto.

(c) Charter Members shall contribute at least \$10,000 in support of the Initiative. As consideration for such contributions, a representative from each Charter Member shall serve on the Advisory Board for CWSA, along with Cal Mutuals' Executive Director. The Advisory Board shall periodically review CWSA's finances and shall approve any expenditures exceeding \$1,000. The Advisory Board shall also consult with Cal Mutuals' Executive Director to ensure the goals of the Initiative are being properly pursued.

2.3. CWSA Participant Issues. Participant shall allow Cal Mutuals to use Participant's name in any correspondence that Cal Mutuals may send regarding the Initiative and in any materials used in soliciting additional members in CWSA; provided, however, that if such correspondence relates to any position CWSA will be taking, including, but not limited to on legislation or regulatory matters, Participant shall be provided the opportunity to opt out of being specifically named in any such correspondence by notifying Cal Mutuals by telephone or e-mail within twenty-four (24) hours after being notified of the position CWSA proposes to take. and If the Participant desires to opt out from being included on any such communication, Cal Mutuals



will remove Participant's name ~~from the communication if so instructed~~. Upon written request of Participant, Cal Mutuals shall promptly (i.e., within three business days) provide Participant by e-mail with a list of all participants in CWSA and their respective contributions.

3.4. Audit/Inspection. Upon at least forty-eight (48) hours' prior written notice, Participant may audit or inspect, at Participant's sole cost and expense, Cal Mutuals' accounting books and records relating to CWSA and the Initiative.

4.5. Term; Termination. This MOU shall have an indefinite term, although it is contemplated to last approximately two years. Because CWSA is intended to be a temporary program, it may be terminated at any time by the vote of at least sixty percent (60%) of its members. Participant may withdraw from CWSA at any time, upon at least seven (7) days' written notice. Such withdrawal shall not entitle Participant to a refund of any portion of its contribution under Section 2, above, unless any audit or inspection under Section 4, above, reveals the misappropriation of funds by Cal Mutuals, in which case CWSA shall be entitled to the return of its entire contribution or such other amount thereof as the parties may agree.

5.6. Indemnification. Cal Mutuals shall indemnify and defend Participant, and its members, directors, officers, employees and agents, against any third party claims, losses, liabilities damages, lawsuits, claims, judgments or other costs resulting from Cal Mutuals' gross negligence or intentional misconduct in performing its duties hereunder. In the event Participant provides employees to render services in conjunction with the Initiative, Participant shall indemnify and defend Cal Mutuals, and its members, directors, officers, employees and agents, against any third party claims, losses, liabilities damages, lawsuits, claims, judgments or other costs resulting from the gross negligence or intentional misconduct of any employee of Participant in rendering such services.

6.7. Notices. Any notice or other communication to be provided under this MOU shall be in writing, and shall be deemed effectively given upon personal delivery; or upon deposit in any United States mail box, by registered, certified, Priority, or Express mail, postage prepaid; or upon delivery by nationally recognized overnight courier; or upon confirmed transmission by facsimile, addressed to the other party at the address shown below.

7.8. Governing Law. This MOU shall be governed by and construed in accordance with the laws of the State of California.

8.9. Amendment. This MOU may be modified only by a written agreement signed by both parties.

9.10. Severability. If any court determines that any provision of this MOU is invalid or unenforceable, any invalidity or unenforceability will affect only that provision and will not make any other provision of this MOU invalid or unenforceable and such provision shall be modified, amended or limited only to the extent necessary to render it valid and enforceable

10.11. Counterparts; Execution Transmitted by E-Mail or Fax. This MOU may be executed in counterparts, effective as of the Effective Date first set forth above. The parties agree

that this MOU will be considered signed when the signature of a party is delivered by e-mail or by facsimile transmission. Such e-mailed or facsimile signature shall be treated in all respects as having the same effect of an original signature.

IN WITNESS WHEREOF, the Participant and Cal Mutuals have executed this MOU as of the date first above written.

California Association of Mutual Water Companies

\_\_\_\_\_  
Participant

By \_\_\_\_\_  
Lisa Yamashita-Lopez, President

By \_\_\_\_\_  
Its \_\_\_\_\_

Address: 1370 N. Brea Blvd., Suite 238  
Fullerton, CA 92835

Address: \_\_\_\_\_  
\_\_\_\_\_

Fax Number: \_\_\_\_\_

Fax Number: \_\_\_\_\_

DRAFT



## Calvin Louie

---

**From:** adan <adan@calmutuals.org>  
**Sent:** Thursday, January 3, 2019 2:34 PM  
**To:** Jones, Paul; Coats, Danielle; Lisa Yamashita Lopez; David A. Armstrong; Jim Ciampa; Ray Kolisz; Dan Ferons; donb@smwd.com; Leach, Jim; Kelly Gardner; Joe A. Gonsalves & Son; Stacy Taylor; Jeff Armstrong; Meggan Valencia; Calvin Louie; Jackie McCloud; Lisa Ohlund; Tim Worley; Nunneley, Doug; mwest@bdvwa.org; Curt Sauer; Reeb, Bob; Dennis Albiani  
**Cc:** Danielle Blacet; Katie Porter; Kelly Jensen; Jim Byerrum; Susan Allen  
**Subject:** CWSA UPDATE & ISSUES TO REVIEW

Team -

Happy New Year! I am writing to report about the status of members and urgent issues that will either result and/or influence potential legislation we are concerned about with respect to meter taxes.

First, as of this date, the following agencies have pending or completed action with their respective boards to approve participation in the Community Water Systems Alliance. These include:

Santa Margarita Water District\*  
Twentynine Palms Water District\*  
Mesa Water District\*  
East Orange County Water District\*  
Cabazon Water District ^  
North of the River Water District#  
Big Horn Water District\*  
Joshua Basin Water District ^  
Eastern Municipal Water District\*

\*denotes Advisory Board Level ^ denotes undetermined level #tiered membership level

Others are pending their internal management evaluation and I will keep you posted. If you run an association and represent agencies with disadvantaged communities, or have neighboring systems, please feel free to refer them and I will call them on your behalf. It is imperative that we have a solid roster of officials from around the state that are elected to represent persons in cities and water districts that are from disadvantaged communities.

### ISSUES

While the legislature returns to session on January 7th., two critical reports have been released for public comment with tight deadlines the first week of February. We are currently reviewing them and will develop draft comment letters for your review. In the meantime here are the links for your study, review and feedback. These two reports will have an influence on continuing legislative discussions about a potential residential/business meter tax to pay for O&M under a current effort to help chronically failing systems, mostly in parts of the Central Valley.

State Water Resources Control Board AB401(Dodd) Low Income Water Rate Assistance Program - This draft report to the legislature outlines options for how the program could be funded and administered. Deadline for comments: Feb 1

[https://www.waterboards.ca.gov/water\\_issues/programs/conservation\\_portal/assistance/](https://www.waterboards.ca.gov/water_issues/programs/conservation_portal/assistance/)

OEHHA Draft Framework and Took for Evaluating Progress on the Human Right to Water

Addresses water quality, access to water, and affordability in the metric for evaluating progress in providing water to all. Deadline for comments: Feb 4

<https://oehha.ca.gov/water/report/human-right-water-california>

We will keep you posted on any further developments.

Best,

Adan

Adan Ortega  
Executive Director  
CalMutuals  
714 449-8403  
[adan@calmutuals.org](mailto:adan@calmutuals.org)

via Newton Mail

On Mon, Dec 3, 2018 at 12:48 PM, adan <[adan@calmutuals.org](mailto:adan@calmutuals.org)> wrote:

Team -

Once again, I'd like to thank Eastern Municipal Water District for hosting a meeting last Friday (Nov. 30) about the possible formation of an alliance of water supply systems that directly represent Disadvantaged Communities and other populations with income limitations. Attached is a document summarizing the discussion we had at Eastern. I think we made great progress to launch this initiative. Please review the principles as I tried to reflect the comments made during the meeting. We are planning to have a conference call during the week of December 10th. If you did not attend the meeting on the 30th but would like to participate on the call during the week of December 10th, please reply to this email and let me know. In the meantime, please feel free to call me if you have any questions (714 600-4683).

Thank you!

Adan Ortega  
Executive Director  
CalMutuals  
714 449-8403  
[adan@calmutuals.org](mailto:adan@calmutuals.org)

via Newton Mail



## Calvin Louie

---

**From:** adan <adan@calmutuals.org>  
**Sent:** Tuesday, January 8, 2019 3:45 PM  
**To:** Calvin Louie; Curt Sauer; Ferons, Dan; donb@smwd.com; Leach, Jim; Nunneley, Doug; Jim Ciampa; Lisa Ohlund; Ray Kolisz; Jim Byerrum; Lisa Yamashita Lopez; Stacy Taylor; Jones, Paul; Coats, Danielle  
**Subject:** CWSA 4 pm meeting documents  
**Attachments:** 2019 CWSA Budget DRAFT 01.03.xlsx; CWSAFlyer.docx

Team -

The calendar notice contains the draft agenda and meeting items. However, realizing that not everyone's system is compatible with google, here they are via email. 

Description: Agenda

1. Review of Participants and Prospective Participants
  - Review of Flyer (Attached)
2. Budget Review (Attached)
3. Advocacy -
  - a. AB401/OEHHA Letters - Preference of Joint Letter or Template for individual use
  - b. Request for list of directors/elected officials who represent DAC divisions/districts
4. Scheduling general meeting and agenda

Adan Ortega  
Executive Director  
CalMutuals  
714 449-8403  
adan@calmutuals.org

Member Contributions	\$72,500-\$85,000	A
Total Income	\$72,500-\$85,000	

<u>EXPENSE</u>	
<b>First Year Activities</b>	
Advocacy & Representation (Lobbyist) Support	20,000
Coordination & Analysis of Issues & Activities (OSG)	18,000
Legal Fees (Lagerlof, Senecal, Gosney & Kruse)	6,000
Travel (Staff & Smaller Members)	8,000
CalMutuals Administrative Fee	6,000
Communications & Graphic Design Support	2,000
<b>Total Expense</b>	<b>60,000</b>

Beginning Reserve	\$12,000-\$25,000	B
Net Total		

NOTES

**A** Reflects contributions of from members as

Big Horn Water District ^	\$2,500-\$10,000	(Monthly)
Cabazon Water District #	\$5,000-\$10,000	(Monthly)
Eastern Municipal Water District *	\$10,000	
East Orange County Water District #	\$10,000	
Mesa Water District #	\$10,000	
North of the River Municipal Water District #	\$5,000	
Santa Margarita Water District *	\$20,000	
Twentynine Palms Water District *	\$10,000	

^ Board Action beginning in January  
 # Board Action completed in January  
 \* Final Action taken

\$72,500-\$85,000

**B** Contributions beyond \$60,000 to be invested in Reserve

- Pending:
- City of Coachella
  - City of Watsonville
  - Coachella Valley Water District
  - Henry Miller Irrigation District
  - Joshua Basin Water District
  - Mojave Water Agency
  - Palmdale Water District
  - Rancho California Water District
  - Santa Ynez Conservation District



Community Water Systems Alliance

The Community Water Systems Alliance is an initiative in California to provide a voice in Sacramento for water systems serving disadvantaged communities that are reliably and affordably providing water to low income and income limited residents such as seniors.

**What We Care About:**

We want to preserve the ability of local water suppliers that provide water to disadvantaged and income limited communities to provide safe and affordable water through efficiency, good management practices and fairness. We care about legislation and regulations that affect disadvantaged and income limited communities where our community voices need to be heard.

**What Threatens Safe Drinking Water for Our Communities:**

Pending legislation may propose to levy water meter taxes that could transfer our local revenues to other parts of the state. The State Water Resources Control Board is soon considering economic feasibility guidelines for evaluating the viability of drinking water standards like Chromium 6.. These two factors may damage the viability of well operated water systems serving disadvantaged communities around the state.

**What do we want?**

Our communities want a seat at the table as legislation and regulations are considered affecting disadvantaged communities so we can advocate for:

- Equitable grant programs that don't discriminate against suppliers serving disadvantaged communities with more than 10,000 customers
- A revenue source to help disadvantaged communities that is not based upon regressive taxes that shift funds from some disadvantaged and income limited communities to others
- Strategies for dealing with chronically failing water systems that don't burden or typecast water systems serving disadvantaged and income limited communities that are functioning well

**Where are we from?**

Participating agencies in CWSA stretch from California's Central Valley, the greater Los Angeles Basin, Coachella Valley and the high desert's Morongo Basin.



# DRAFT

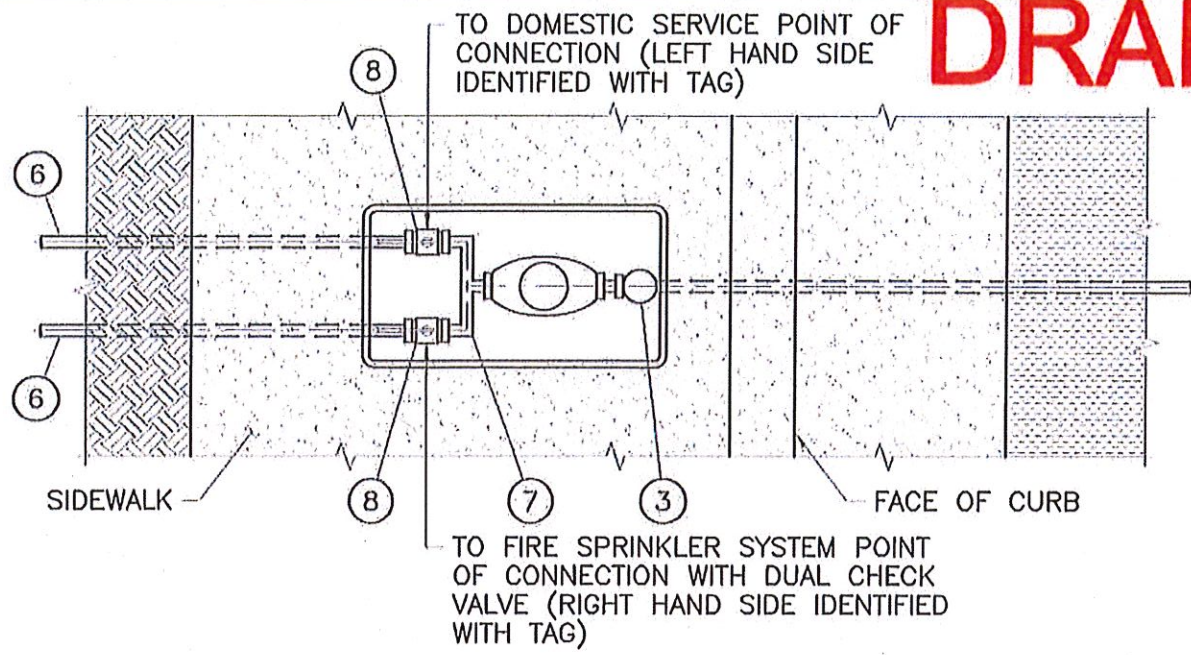

## PLAN

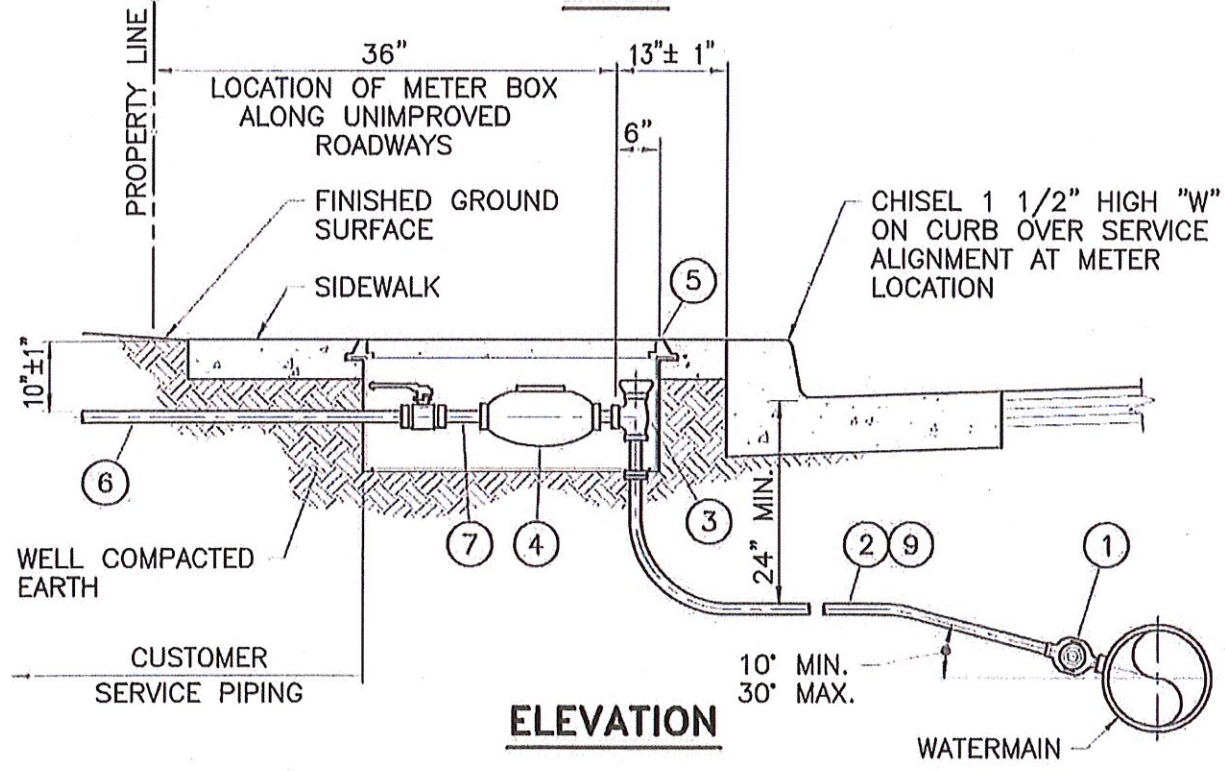

## ELEVATION

APPROVED BY	
DISTRICT WATER ENGINEER	RCE No.      DATE
RECOMMENDED BY	
GENERAL MANAGER	DATE
REVISION	BY      DATE

**CABAZON WATER DISTRICT**  
CABAZON, CALIFORNIA

---

**1" DUAL SERVICE INSTALLATION**

---

**STANDARD DRAWING W126A**



# DRAFT

ITEM	NO. REQ'D.	DESCRIPTION	APPROVED MATERIAL LIST NO.
1	1	1" SERVICE CONNECTION PER STANDARD DRAWING W124 OR STANDARD DRAWING W125.	SEE DWG. W124 OR DWG. W125
2	VARIES	1" TYPE "K" SOFT COPPER TUBING.	A-05
3	1	1" ANGLE METER STOP.	B-05
4	1	METER (SIZE AS SPECIFIED).	H-18
5	1	METER BOX.	E-01
6	1	1" STANDARD WEIGHT BRASS PIPE, 12" LONG.	A-06
7	1	1" FEMALE METER SWIVEL NUT x 1" x 1" MALE METER THREAD BRASS TEE.	N/A
8	1	1" BALL VALVE ASSEMBLY WITH 3 1/4" LONG HANDLE AND 2 LOCK EARS WITH IDENTIFICATION TAG.	B-08
9	1	ONE INLINE COUPLING MAY BE PERMITTED WHEN APPROVED BY DISTRICT.	H-12

NOTES:

1. COPPER SERVICE TUBING SHALL BE LAID STRAIGHT AND AT RIGHT ANGLES TO THE WATERMAIN.
2. METER BOX SHALL BE AT LEAST 5' FROM EDGE OF DRIVEWAY (CURB DROP) OR FROM DRIVEWAY RADIUS.
3. PIPE THREADS SHALL BE CLEAN AND SHARP AND SEALED WITH AN APPROVED JOINT COMPOUND.
4. METER BOX MAY BE PLACED BEHIND CURB OR BEHIND SIDEWALK. DISTRICT WILL SPECIFY LOCATION OF METER BOX.

APPROVED BY	CABAZON WATER DISTRICT CABAZON, CALIFORNIA		
DISTRICT WATER ENGINEER	RCE No.	DATE	1" DUAL SERVICE INSTALLATION
RECOMMENDED BY	GENERAL MANAGER		
	DATE		STANDARD DRAWING W126B
REVISION	BY	DATE	



*Cabazon Water District*

14618 Broadway Street • P.O. Box 297  
Cabazon, California 92230

## Summary of Water Facilities Charges

This table summarizes the total charges required for water service to accommodate new water connections up to and including a 2 inch water meter service:

<b>Meter Size (Inches)</b>	<b>Capacity Charge Per Meter (\$)</b>	<b>Service Connection Charge Per Meter (\$)</b>	<b>Total Charges (\$)</b>
5/8 x 3/4	8,136	1,170	9,306
3/4	12,204	1,180	13,384
1	20,340	1,240	21,580
1-1/2	40,679	1,900	42,579
2	65,087	2,000	67,087

Business (951) 849-4442 • FAX (951) 849-2519



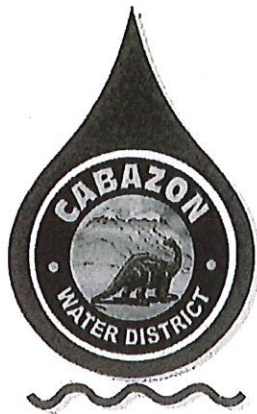

## Current Water Rates Effective December 1, 2018

Meter Size	Monthly Service Charge
5/8"	\$ 61.77
3/4"	\$ 89.10
1"	\$ 143.78
1-1/2"	\$ 280.46
2"	\$ 444.48
3"	\$ 881.88
4"	\$ 1373.94
6"	\$ 2740.80
Contract Customer	\$ 2025.45

### Monthly Commodity Charge

Tier 1: 0-700 ft <sup>3</sup>	\$1.39 per 100 cubic feet
Tier 2: 800-1,400 ft <sup>3</sup>	\$3.04 per 100 cubic feet
Tier 3: Over 1,400 ft <sup>3</sup>	\$4.42 per 100 cubic feet
Contract Customer	\$4.64 per 100 cubic feet

**RECORDING REQUESTED BY:**

CABAZON WATER DISTRICT

**AND WHEN RECORDED MAIL TO:**

Best Best & Krieger LLP  
Attn: Steven M. Anderson, Esq.  
3390 University Ave.  
5th Floor  
Riverside, CA 92501

(Space above line for County Recorders use only)

*No recording fees required pursuant to Rev. & Tax. Code, § 11922; Gov. Code § 27383*

**WAIVER, RELEASE AND INDEMNITY AGREEMENT**

THIS WAIVER, RELEASE AND INDEMNITY AGREEMENT (hereinafter, "Agreement") is made and entered into this \_\_\_\_ day of \_\_\_\_\_, 2019 ("Effective Date") by and between the Cabazon Water District ("District"), \_\_\_\_\_ ("Developer") and \_\_\_\_\_ ("Customer"), (collectively, the "Parties" and individually, the "Party").

A. Customer and Developer each desires to obtain water service from the District, including meter installation, related to that certain real property known as APN \_\_\_\_\_, and located at \_\_\_\_\_, Cabazon, California ("Property"), as described in Exhibit "1", attached.

B. Customer and Developer each acknowledges and understands that fire suppression services provided to the Property by a fire protection agency may utilize fire hydrants in proximity to the Property.

C. Customer and Developer each understands and acknowledges all of the following: (i) fire hydrants utilized to suppress fires affecting the Property may not provide fire flows equal to those set forth in Article 12 of the District's Rules and Regulations Governing Water Service; (ii) upgrading or otherwise achieving fire flow rates set forth in Article 12 would be costly and time consuming for the District; and (iii) Customer and Developer do not at the present wish to incur costs associated with achieving fire flow rates as prescribed by the District's Rules and Regulations Governing Water Service.

D. District hereby agrees to install a meter for water service to the Property subject to the terms and conditions set forth herein.

E. In the event future water demands relating to the Property require installing a larger water meter than the meter contemplated by this Agreement and related will-serve letter, Customer and Developer hereby agree to be responsible for any additional costs and District fees associated with installing the larger meter, as determined at the time the larger meter is installed.

F. In consideration of this Agreement and to the fullest extent permitted by law, each of Customer and Developer and their respective successors, assigns, principals, agents, employees,



consultants, representatives, bonding companies and insurers hereby release, forever discharge and waive any and all claims as against District, District's officers, successors, assigns, principals, agents, employees, consultants, representatives, attorneys, bonding companies and insurers from any and all liability, demands, causes of actions, or responsibility of any kind for claims, known or unknown, arising out of or in any way related to the provision of water service by the District, including but not limited to the provision of fire flow, to the Property ("Released Claims").

G. With respect to the Released Claims, Customer and Developer specifically each waives the provisions of Section 1542 of the California Civil Code, and any other similar statute or provision, which provides as follows:

**A GENERAL RELEASE DOES NOT EXTEND TO CLAIMS WHICH THE CREDITOR DOES NOT KNOW OR SUSPECT TO EXIST IN HIS OR HER FAVOR AT THE TIME OF EXECUTING THE RELEASE, WHICH IF KNOWN BY HIM OR HER MUST HAVE MATERIALLY AFFECTED HIS OR HER SETTLEMENT WITH THE DEBTOR.**

Customer and Developer each expressly waives and releases any right or benefit which Customer and Developer each has or may have under Section 1542 of the Civil Code of the State of California, to the full extent that such rights and benefits may be waived.

H. In consideration of this Agreement and to the fullest extent permitted by law, Customer and Developer each hereby agrees to indemnify, defend and hold District, its officers, employees, consultants, contractors and agents harmless from any damage, claim, liability, or cost (including attorney's fees and costs of defense) to the extent caused by, arising from or in any way related to the provision of water service by the District, including but not limited to the provision of fire flow, to the Property.

I. Each of the Parties hereby agrees that this Agreement is intended to be interpreted as broadly and inclusively as is permitted by the laws of the State of California, and that if any provision or portion thereof is held invalid, illegal, or otherwise unenforceable by a court of competent jurisdiction, it is agreed that the balance of the Agreement shall continue in full legal force and effect.

J. Customer and Developer each agrees that this Agreement shall be binding on his/her heirs, successors and assigns, including without limitation, future owners of the Property.

K. Customer and Developer, by signing below, each acknowledges that it has read and hereby voluntarily signs this Agreement, and that no oral representations, statements or inducement, apart from the foregoing written agreement, has been made, and that the undersigned possesses the legal power, right, and authority to bind each of Customer and Developer, respectively. Customer and Developer each further acknowledges that each of Customer and Developer understands that by signing this Agreement may be waiving valuable legal rights and that Customer and Developer, respectively, may at any time seek the advice of an attorney in any matter connected with this Agreement prior to signing.



IN WITNESS WHEREOF, the undersigned each hereby executes this Waiver, Release and Indemnity Agreement and make it effective as of the date first written above.

"District":	"Customer":	"Developer":
<b>Cabazon Water District</b>	[REDACTED]	[REDACTED]
By: _____	By: _____	By: _____
Name: _____	Title: _____	Name: _____
Title: _____	Dated: _____	Title: _____
Dated: _____		Dated: _____

DRY

**EXHIBIT 1**

**Legal Description of APN 526-201-017**

LOT 164 OF CABAZON VISTA, IN THE COUNTY OF RIVERSIDE, STATE OF CALIFORNIA, AS SHOWN BY MAP ON FILE IN BOOK 44, PAGES 21 AND 22 OF MAPS, RECORDS OF RIVERSIDE COUNTY, CALIFORNIA.

**DRAFT**

**NOTARY ACKNOWLEDGMENT**  
(California All-Purpose Acknowledgment)

STATE OF CALIFORNIA            )  
  ) ss.  
COUNTY OF \_\_\_\_\_ )

On \_\_\_\_\_, 201\_\_ before me, \_\_\_\_\_, notary public,  
personally appeared \_\_\_\_\_, who proved to me on the basis of satisfactory  
evidence to be the person(s) whose name(s) is/ate subscribed to the within instrument and  
acknowledged to me that he/she/they executed the same in his/her/their authorized capacity(ies),  
and that by his/her/their signature(s) on the instrument the person(s), or the entity upon behalf of  
which the person(s) acted, executed the instrument.

I certify under PENALTY OF PERJURY under the laws of the State of California that  
the foregoing paragraph is true and correct.

WITNESS my hand and official seal.

\_\_\_\_\_  
Signature of Notary Public



